



Scan for full manual

VIA Campus² PLUS Quick Start Guide For Installer

This guide helps you install and configure your VIA Campus² PLUS for the first time.

Go to [www.kramerav.com/product/VIA Campus² PLUS](http://www.kramerav.com/product/VIA_Campus2_PLUS) to download the latest user manual and check if firmware upgrades are available.

Step 1: Check what's in the box

- ✓ VIA Campus² PLUS Collaboration Device
- ✓ HDMI cable extender (M to F)
- ✓ 2 Wi-Fi antennas
- ✓ 1 Power adapter (19V DC)
- ✓ 1 Quick start guide

Step 2: Get to know your VIA Campus² PLUS

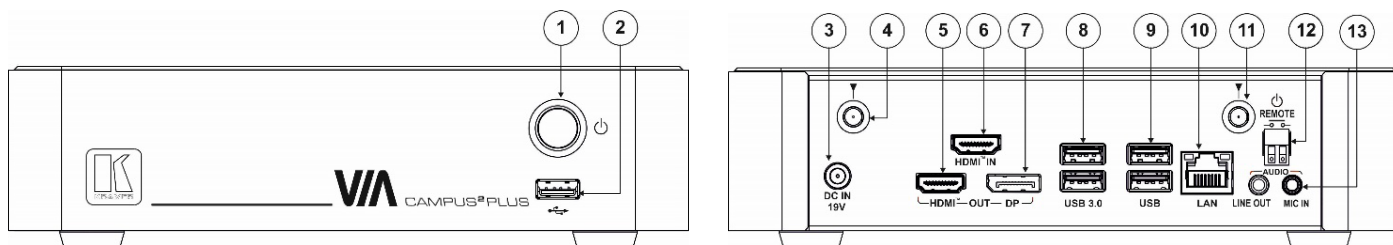

#	Feature	Function
1	Power Button	For turning the unit on and off.
2	USB 2.0 Connector	For upgrading firmware or connecting a USB device.
3	DC IN 19V Connector	Connects to the 19V DC power adapter.
4	Wi-Fi Antenna Port (1 of 2)	Connect one of the Wi-Fi antennas for collaborating via the built-in Wi-Fi.
5	HDMI OUT Connector	Connect to an HDMI display.
6	HDMI IN Connector	Connect to an HDMI source (for example, a laptop).
7	DP OUT Connector	Connect to a DisplayPort display.
8	USB 3.0 connectors	Connect to up to 2 USB devices.
9	USB 2.0 connectors	Connect to up to 2 USB devices.
10	LAN RJ-45 Connector	Connect a Local Area Network (LAN) cable.
11	Wi-Fi Antenna Port (2 of 2)	Connect one of the Wi-Fi antennas for collaborating via the built-in Wi-Fi.
12	REMOTE 2-pin Terminal Block	Connect to a toggle switch to remotely turn the device on and off.
13	AUDIO	
	LINE OUT 3.5mm Mini Jack	Connect to an unbalanced stereo audio acceptor.
	MIC IN 3.5mm Mini Jack	Connect to a microphone.

Step 3: Mount VIA Campus² PLUS

Install VIA Campus² PLUS using one of the following methods:

- Mount the unit in a rack using the recommended rack adapter (see [www.kramerav.com/product/VIA Campus² PLUS](http://www.kramerav.com/product/VIA_Campus2_PLUS)).
- Place the device on a flat surface.



Ensure that the environment (e.g., maximum ambient temperature & air flow) is compatible for the device.
Avoid uneven mechanical loading.
Appropriate consideration of equipment nameplate ratings should be used for avoiding overloading of the circuits.
Reliable earthing of rack-mounted equipment should be maintained.

Step 4: Connect inputs and outputs

Always switch OFF the power on each device before connecting it to your **VIA Campus² PLUS**.

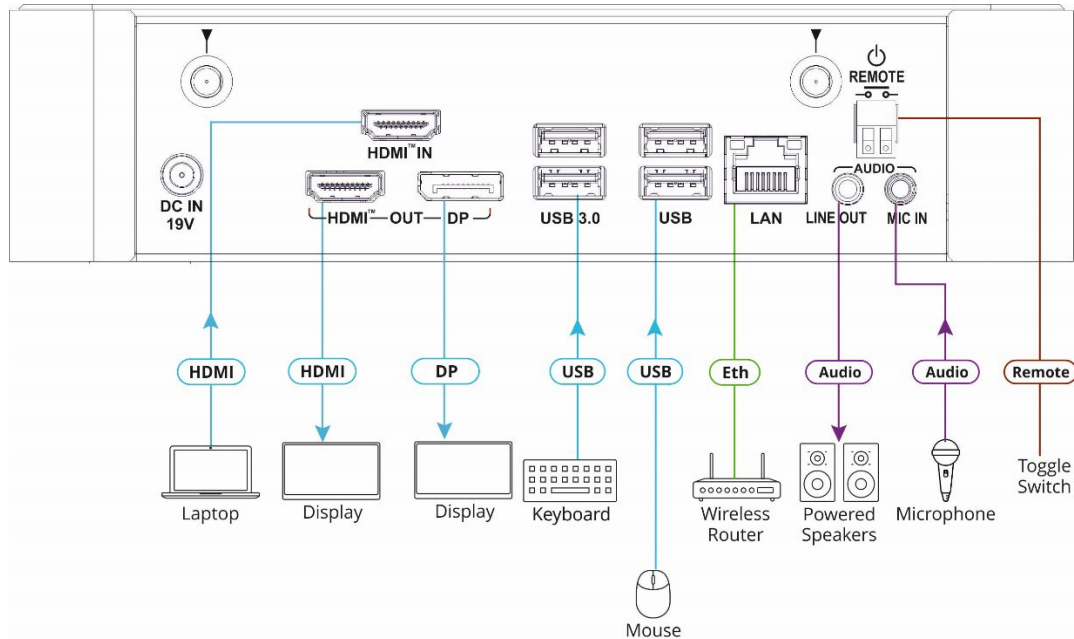

1. Connect the keyboard and mouse.
2. Connect an HDMI display and/or a DisplayPort display.
3. Connect a laptop or other HDMI source.
4. Connect a Local Area Network (LAN) cable for connection to your network.
5. Connect the Wi-Fi antennas for using the built-in wireless capability.
6. Connect powered speakers and a microphone.



To achieve specified extension distances, use Kramer cables available at [www.kramerav.com/product/VIA Campus² PLUS](http://www.kramerav.com/product/VIA_Campus²_PLUS). Using third-party cables may cause damage!

Step 5: Connect power

Connect the 19V DC power adapter to **VIA Campus² PLUS** and plug it into the mains electricity.



- Caution:** There are no operator serviceable parts inside the unit.
 - Caution:** The device is intended to be installed at a height of 2 meters or less.
 - Warning:** Use only the Kramer Electronics power adapter that is provided with the unit.
 - Warning:** Disconnect the power and unplug the unit from the wall before installing.
- See www.KramerAV.com for updated safety information.

Step 6: Configure VIA Campus² PLUS

A wizard guides you through configuration. For more information about configuration see “**For Web Administrator: Gateway Management pages**” in the User Manual.

If you choose to skip the wizard, follow these steps for configuration:

1. Click the VIA tile at the bottom left of the screen: The Gateway Dashboard will open.
2. On the **Kramer Gateway Dashboard**, click **Settings**: The settings login window appears.
3. Enter the User Name (default = su) and Password (default = supass) and click **Login**: The VIA Settings window appears.

The VIA Settings tabs are:

- LAN Settings – Configure network parameters (default = DHCP allocated IP).
- System Controls – Manage your display and audio settings.
- Wifi – Choose between **AP Mode** and **Client Mode**: AP Mode sets the **VIA Campus² PLUS** as an independent Wi-Fi network, Client Mode connects the **VIA Campus² PLUS** to an existing Wi-Fi network, making it a secondary access point for guests.

4. When you have finished configuring settings, click **Reboot** to apply all settings.

VIA

Login:

User Type: Super User General User

User Name:

Password:



Scan for full manual

VIA Campus² PLUS Quick Start Guide For User

This guide helps you participate in a meeting with your VIA Campus² PLUS for the first time.

Go to [www.kramerav.com/product/VIA Campus² PLUS](http://www.kramerav.com/product/VIA_Campus2_PLUS) to download the latest user manual.

Step 1: Connect your personal device to the proper network

Connect your personal device to the built-in VIA Campus² PLUS Wi-Fi network or to the same LAN / Wi-Fi network used by the specific VIA Campus² PLUS device in your meeting room.

Step 2: Run or Download the Kramer VIA app

See “Installing or Running the VIA app” in the User Manual.

For Mac or PC:

1. Enter the Room Name of the VIA Campus² PLUS device into your computer’s browser. The Welcome page appears.

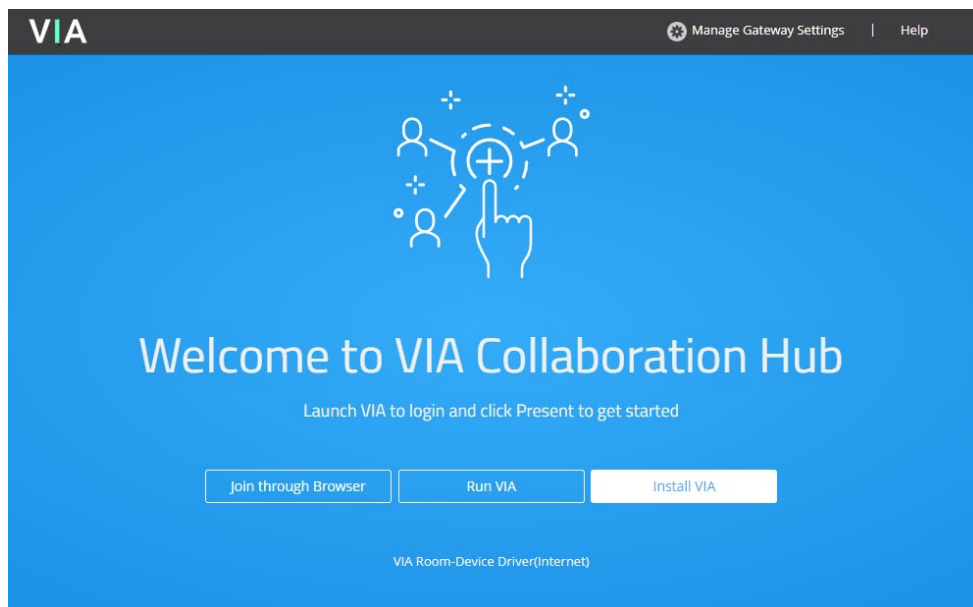

2. Click **Run VIA** to execute the **Kramer VIA** app without downloading it (for guests using VIA temporarily).
OR Click **Install VIA** to download the **Kramer VIA** app onto your computer (for regular users of VIA).

For iOS or Android devices: Download and install the free **Kramer VIA** app from Apple App Store or Google Play.

For Chromebook or Chrome Browser: Click **Join through browser** on the Welcome page.

Step 3: Join the meeting using Kramer VIA App

See “Joining a Room with the VIA app” in the User Manual.

1. Open the Kramer VIA app and select the room to which you want to connect. The Room code window appears.
2. In the Room Code field, enter the 4-digit code as it appears on the main display (if enabled).
3. You are logged into the VIA meeting. The VIA Dashboard (and taskbar icon for laptops) appears on your device screen.

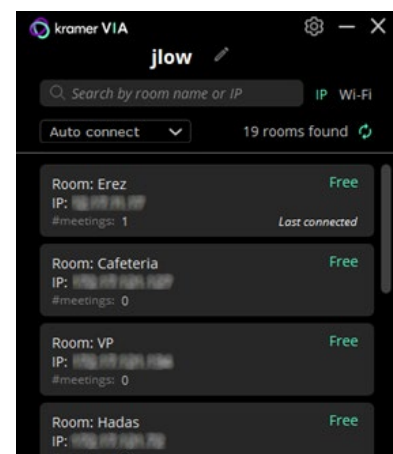

Step 4: Using the VIA dashboard menu

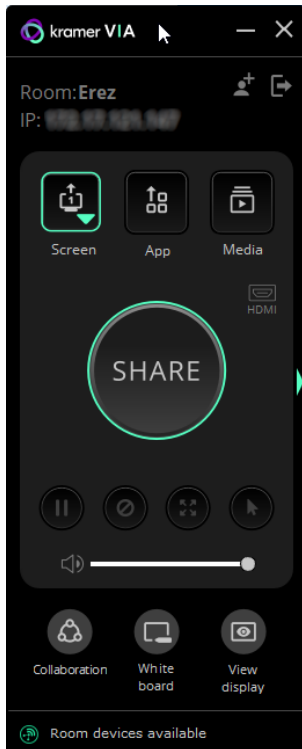

For more information see “Presenting from the VIA User Dashboard” in the User Manual.

1. Select what you want to share:
 - **Screen** – Share your screen.
 - **App** – Share a window or app that you are using.
 - **Media** – Share (stream) a media file.







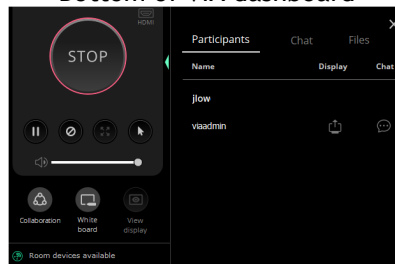



















2. Click SHARE:
 - The SHARE button becomes the STOP button.
 - Your screen, app or media will be displayed to meeting participants (on the main display).
3. Click the green arrow on the right to view participants, chat or to send files.

Bottom of VIA dashboard



4. Use the 4 buttons below STOP to control sharing.
5. Use the 3 buttons at the bottom for collaborating with other participants.
6. Click STOP to end sharing.

VIA Campus² PLUS Features

 Wireless Connection	 Recording	 Whiteboard	 Full HD Video Streaming	 Third-Party Apps	 Powerful Content Security
 Native ePolling	 Chat	 Integrated YouTube Player	 Digital Signage	 Mobile Mirroring	 Web Browser
 Enable Control	 Do Not Disturb (DND)	 View Main Display	 VIA Site Management (VSM)	 4K Output	 Windows PC Operating Platform
 Customizable Features	 Streaming Output	 File Sharing	 File Storage	 Customizable Screen Layout	 VIA Pad Compatible

Specifications are subject to change without notice at www.kramerav.com

The terms HDMI, HDMI High-Definition Multimedia Interface, and the HDMI Logo are trademarks or registered trademarks of HDMI Licensing Administrator, Inc.

SIMPLIFIED EU DECLARATION OF CONFORMITY

Hereby, Kramer Electronics declares that the radio equipment type VIA Campus2PLUS is in compliance with Directive 2014/53/EU.

The full text of the EU declaration of conformity is available via the Resources tab on the product page at the following internet address:

<https://www1.kramerav.com/product/VIACampus2PLUS>